

SAGF

BLACK TOP TRAMPOLINE CODE

(Updated 11 June 2017)



BLACK-TOP CODE

1. COMPETITIONS

Competitions are held in the following age groups for girls and boys:
6–7 years 8–9 years 10–12 years 13–14 years 15 years and over

(Black-Top Routines are the same for all levels & age groups)

Competition Attire

A team must wear the same club, regional or provincial dress

Girls: Leotard and bare feet or trampoline shoes

Boys: Leotard with “short” shorts and bare feet or trampoline shoes

Exception to this rule is made for new clubs and/or schools that compete in individual competition. Their clothing attire will be:

Girls and boys could jump in a neat T-shirt and a short (shorts should be above knee height and shirts should be tucked in to enable judges to see the gymnast's body position in the air). However, all the members of the club or regional team must wear “look-alike” T-shirts and shorts.

Pre-Requisite

A gymnast should be able to do 10 straight jumps on the trampoline – high, rhythmic and controlled with no displacement on the trampoline. Progress to Black Top level 1 skills to teach correct body position. Skills to be taught according to FIG skill progression

2. BLACK TOP ROUTINES

Voluntary Routines

Prescribed routines are performed first, followed by the voluntary routine. Level 1,2, 3 highest competition “Zone”. **ALL** beginners should start at level 1. All level 1 routines to end with an outbounce. **Please note that the out bounce in prescribed routines will be judged for displacement 0.1 – 0.3 and that in the event of a missing out bounce that 0.3 will be deducted from each execution judge.**

The numbers of skills in a prescribed & voluntary routine are as follows:

5 skills – Level 1	8 skills Level 2	10 skills Level 3
6 -7 years	6 -7 years	12 years & younger
8 – 9 years	8 – 9 years	13 years & older
10 – 12 years	10 – 12 years	
13 - 14 years	13 - 14 years	
15 years & over	15 years & over	

NB – According to SAGF rules a gymnast aged 5 years and younger cannot participate in any official event however, talented gymnasts can still compete in club competitions and will participate in the first age group 6-7 years,

Only half or junior colours can be awarded for levels 1,2 and 3

Limitations

Please note that the limitations for each level are reflected under the routines for that level.

Coaching qualification:

Due to the nature and difficulty of skills performed in elite routines, any gymnasts who attempts the elite routines and want to compete in the elite sections, are required to be coached by a coach who has at least a level 1 coaching accreditation, preferably level 2.

LEVEL 1

6 – 7 years

1	Tuck Jump	0.0
2	½ Turn	0.1
3	Seat Drop	0.0
4	To Feet	0.0
5	Straddle Jump	0.0
	Out bounce	
	TOTAL	0.1

8 – 9 years

1	Tuck Jump	0.0
2	½ Turn	0.1
3	Seat Drop	0.0
4	To Feet	0.0
5	Straddle Jump	0.0
	Out bounce	
	TOTAL	0.1

10 – 12 years

1	Tuck Jump	0.0
2	½ Turn	0.1
3	Seat Drop	0.0
4	To Feet	0.0
5	Straddle Jump	0.0
	Out bounce	
	TOTAL	0.1

13 - 14 years

1	Tuck Jump	0.0
2	½ Turn	0.1
3	Seat Drop	0.0
4	To Feet	0.0
5	Straddle Jump	0.0
	Out bounce	
	TOTAL	0.1

15 years and Over

1	Tuck Jump	0.0
2	½ Turn	0.1
3	Seat Drop	0.0
4	To Feet	0.0
5	Straddle Jump	0.0
	Out bounce	
	TOTAL	0.1

Limitations to level 1 routine:

Please note that somersaults are prohibited.

LEVEL 2

6 – 7 years

1	Tuck Jump	0.0
2	Seat Drop	0.0
3	To Feet	0.0
4	Pike Jump	0.0
5	Hands & Knees	0.1
6	To Feet	0.1
7	Straddle Jump	0.0
8	Pirouette	0.2
	Out bounce	
	TOTAL	0.4

8 – 9 years

1	Tuck Jump	0.0
2	Seat Drop	0.0
3	To Feet	0.0
4	Pike Jump	0.0
5	Hands & Knees	0.1
6	To Feet	0.1
7	Straddle Jump	0.0
8	Pirouette	0.2
	Out bounce	
	TOTAL	0.4

10 – 12 years

1	Tuck Jump	0.0
2	Seat Drop	0.0
3	To Feet	0.0
4	Pike Jump	0.0
5	Hands & Knees	0.1
6	To Feet	0.1
7	Straddle Jump	0.0
8	Pirouette	0.2
	Out bounce	
	TOTAL	0.4

13 - 14 years

1	Tuck Jump	0.0
2	Seat Drop	0.0
3	To Feet	0.0
4	Pike Jump	0.0
5	Hands & Knees	0.1
6	To Feet	0.1
7	Straddle Jump	0.0
8	Pirouette	0.2
	Out bounce	
	TOTAL	0.4

15 years and over

1	Tuck Jump	0.0
2	Seat Drop	0.0
3	To Feet	0.0
4	Pike Jump	0.0
5	Hands & Knees	0.1
6	To Feet	0.1
7	Straddle Jump	0.0
8	Pirouette	0.2
	Out bounce	
	TOTAL	0.4

Limitations to level 2 routines:

Somersaults: Somersaults with a rotation of more than 450 degrees will not be allowed

Twisting: Back somersaults with twisting of more than 360 degrees will not be allowed. Front somersaults with twisting of more than 540 degrees will not be allowed

LEVEL 3

12 years and younger

1	Back Drop	0.1
2	To Feet	0.1
3	Straddle Jump	0.0
4	Seat Drop	0.0
5	½ Twist To Seat	0.1
6	To Feet	0.1
7	Pirouette	0.2
8	Tuck Jump	0.0
9	Stomach Drop	0.1
10	To Feet	0.1
	Out bounce	
	TOTAL	0.8

13 years and Over

1	Back Drop	0.1
2	To Feet	0.1
3	Straddle Jump	0.0
4	Seat Drop	0.0
5	½ Twist To Seat	0.1
6	To Feet	0.1
7	Pirouette	0.2
8	Tuck Jump	0.0
9	Stomach Drop	0.1
10	To Feet	0.1
	Out bounce	
	TOTAL	0.8

Limitations to level 3 routines:

Somersaults: Somersaults with a rotation of more than 630 degrees will not be allowed

Twisting: Back somersaults with twisting of more than 360 degrees will not be allowed. Front somersaults with twisting of more than 540 degrees will not be allowed

3. RULES & REGULATIONS

- 3.1 Repetition of skills on the black top trampoline are not allowed in any of the routines. A skill performed in one routine may be performed again in the other routine.

When a skill is repeated in a compulsory routine - the routine will be terminated, where the incorrect skill was performed

When a skill is repeated and:

- the skill has no difficulty value or a value lower than 0.5 a deduction of 0.5 will be made by the difficulty judge
- if the difficulty of the skill is higher than 0.5 the full difficulty of the skill will be lost.

- 3.2 Warm-up time is within the discretion of the organisers and depends on time and availability of equipment. Warm-up should not be used as a training session and any abuse of the warm-up time will incur a penalty of 0.3 from each execution judge in the first routine.
- 3.3 If there are 10 or more competitors in a group, there will be a preliminary and a final round. The competitors will be divided into flights and the voluntary routine will serve as the preliminary round. The ten competitors with the highest scores (execution plus difficulty) progress to the final.
- 3.4 The prescribed routine will be performed in the final round. If competition time allows all gymnasts may be allowed to perform both routines, however this is up to the discretion of the competition organisers.
- 3.5 The same panel of judges must judge all the flights for a specific group.
- 3.6 Before the final, the competitors should be allowed to warm up their prescribed routine once, depending on the arrangements of the organisers, time and availability of warm-up equipment. The scores from the preliminary round are carried over and added to the competitor's final score to determine the total score.
- 3.7 Trampoline competitors are not allowed to participate in competitions on the black top trampoline.
- 3.8 Gymnasts who participate on the black top trampoline may not be awarded provincial colours, only junior or ½ colours.
- 3.9 The winner of the competition will be the gymnast with the highest total score for both routines (execution for both routines and difficulty for the first routine is added). Any tie will be broken according to the SA TRA tie breaking rules, i.e. there will only be one gold, silver and bronze medallist per category.

4. DEDUCTIONS

Execution of the routines are marked out of the amount of skills in the prescribed routine.

4.1. Deductions on instruction of the chair of judges

- | | | |
|-------|---|-----------------------------|
| 4.1.1 | After landing, touching the bed with one or both hands | 0.5 pts |
| 4.1.2 | After landing, touching with or falling to the knees, hands & knees, front, back or seat on the bed. | 1.0 pts |
| 4.1.3 | Touching or stepping out on anything other than the trampoline bed. | 0.5 pts |
| 4.1.4 | Landing/falling on the outside of the trampoline bed, leaving the trampoline area, or performing an additional somersault. | 1.0 pts |
| 4.1.5 | Talking to or giving any form of signal to a gymnast by their own spotters or coach during the routine, for each occurrence | 0.6 pts |
| 4.1.6 | Additional elements | 2.0 pts |
| 4.1.7 | Exceeding the time limit | |
| | 61 seconds | 0.2 pts |
| | 91 seconds | 0.4 pts |
| | 121 seconds | 0.6 pts |
| | 181 seconds | disqualified from the round |

4.2 interruptions – a routine will be considered interrupted if a gymnast

- 4.2.1 Obviously does not land simultaneously on both feet on the trampoline bed.
- 2.2.2 Does not use the elasticity of the bed after landing for the immediate continuation of the next element.
- 2.2.3 Performs an intermediate (straight) jump.
- 2.2.4 Lands on any part of the body except feet, seat, front or back.
- 2.2.5 Performs an incomplete element.
- 2.2.6 Touches anything other than the trampoline bed with any part of the body.
- 2.2.7 Is touched by a spotter or spotter mat.
- 2.2.8 Leaves the trampoline due to insecurity.
- 2.2.9 Does not perform a prescribed compulsory routine using the required elements and/or in the required sequence.
- 2.2.10 No credit will be given for the element in which the interruption occurs.
- 2.2.11 A gymnast will be judged only on the number of elements completed on the trampoline bed.
- 2.2.12 The Chair of Judges Panel will decide the maximum mark.

4.3 Termination of a routine

- 4.3.1 The routine must end under control in an upright position, with both feet on the trampoline bed, otherwise there will be a deduction (see 4.4.2)
- 4.3.2 After landing on the bed, the gymnast must stand upright for approximately 3 (three) seconds, otherwise there will be a deduction for lack of stability (see 4.4.2)
- 4.3.3 A routine is deemed to have ended only after the time as per 4.3.2, have elapsed
- 4.3.4 The gymnast is allowed to do 1 (one) more jump in a stretched position (out-bounce) after the last element, using the elasticity of the bed.
- 4.3.5 If the gymnast executes more than 5 (five), 8 (eight), or 10 (ten) movements, according to the relevant age group, a deduction of 1.0 points will be made (see 4.1.7)..

4.4 Deductions by the judges for execution

- 4.4.1 Lack of form, consistency of height & control : 0.1 – 0.5 points per skill (see Appendix for guidelines on lack of form)
- 4.4.2 Lack of stability - after dismount : 0.1 – 0.2 points

4.5 Actions and deductions by the difficulty judge

- 4.5.1 Check prescribed routines. When a competitor does not perform the correct prescribed routine for the event, bring it to the attention of the superior judge. Routine is interrupted when incorrect skill is performed.
- 4.5.2 Check for repeats. Deduction of 0.5 for a repeat where difficulty is less than 0.5. If difficulty is higher than 0.5 the total difficulty is forfeited.

5. JUDGING PANEL

The judging panel consists of: One Superior Judge, 4 Execution judges, + 2 displacement judges + 2 difficulty judges Minimum (for club competitions) - 2 Execution judges, 1 displacement judge, 1 difficulty judge

6. SCORING

The total score of a competitor is calculated as follows:

Add the two scores of the execution judges together (*if four judges, discard the highest and lowest mark and add the two middle scores together*)

Add the average of the two horizontal displacement judges (*Or take the full score if only one judge*)

Add difficulty where applicable

For total score add the scores for both routines together (*round total to 2 decimals*).

APPENDIX

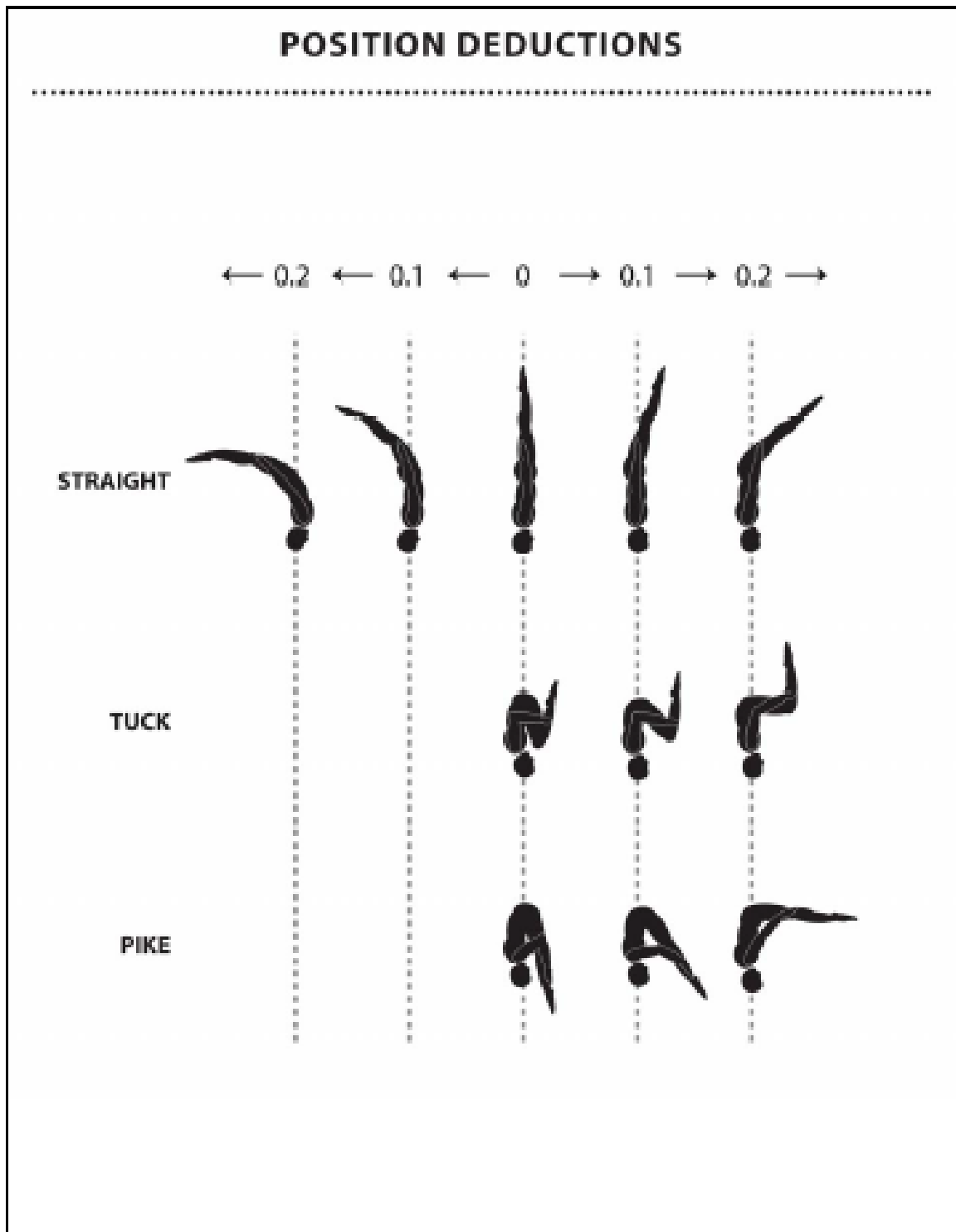

OPENING

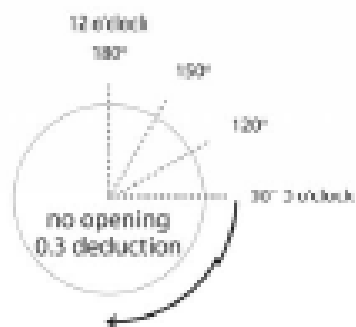
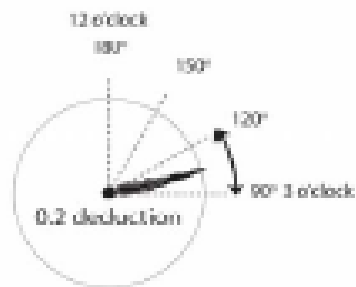
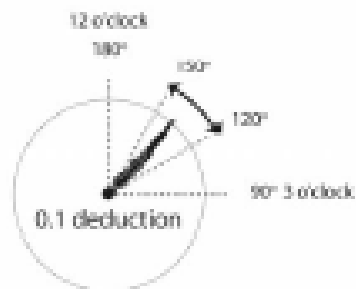
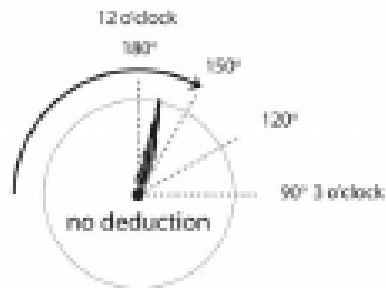

AFTER OPENING

PIKE DOWN

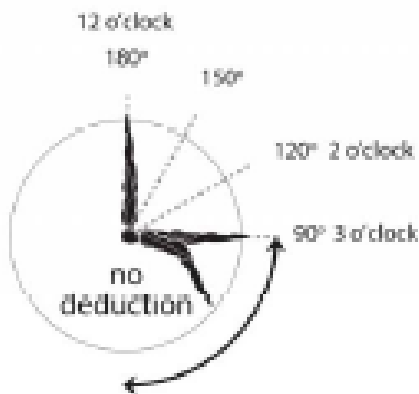
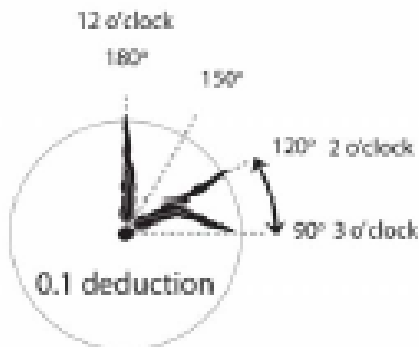
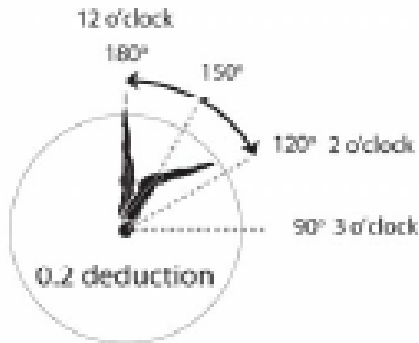

TUCK DOWN

